

# Chapitre 4

# Carte

# Curiosity HPC

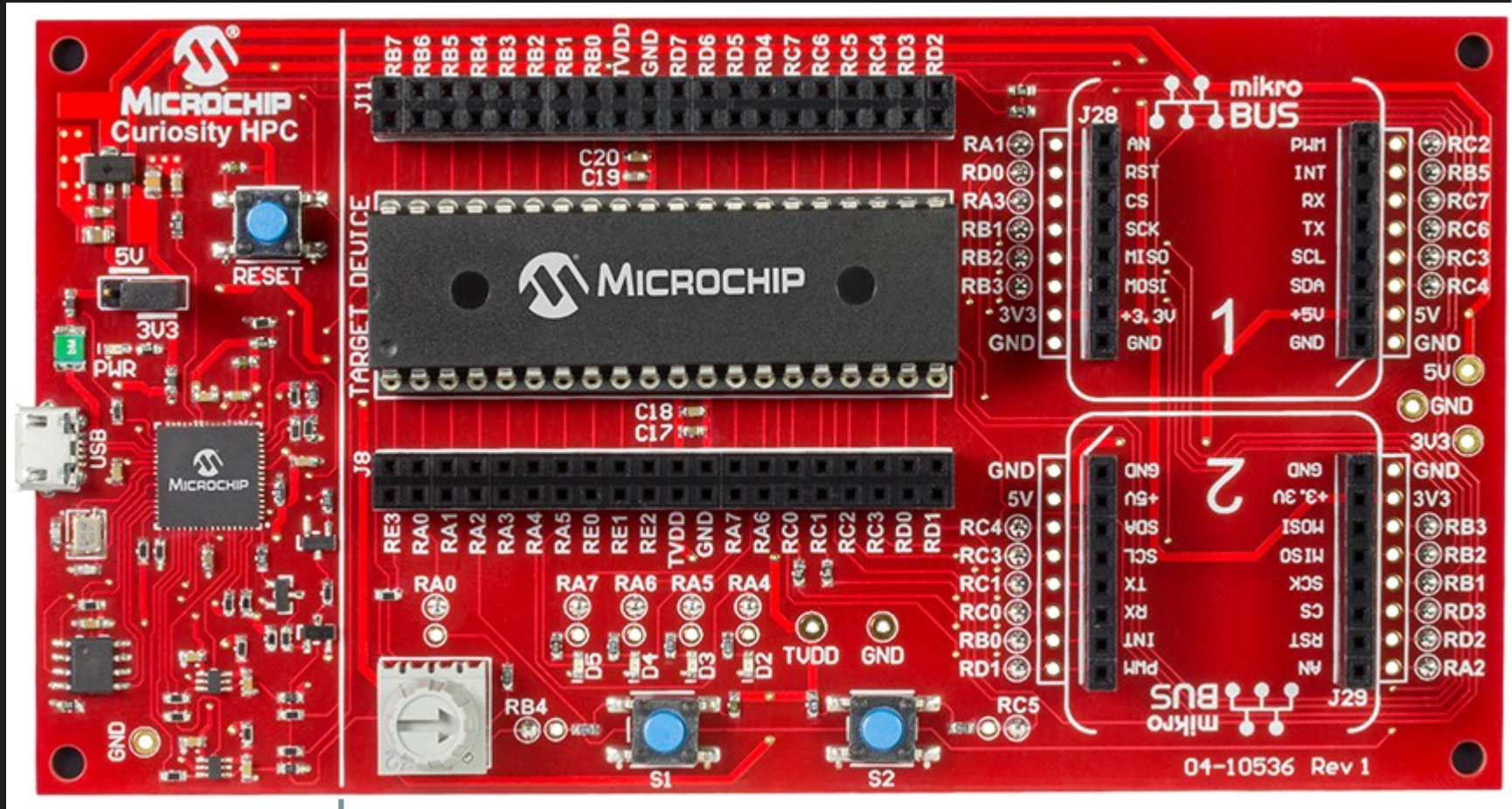



Programmer  
Debugger

Application

## Sonde JTAG

En l'absence de bootloader dans le processeur, nous devons utiliser une sonde **JTAG** (*Join Test Action Group*), qui permet de charger et debugger un programme depuis l'IDE vers le MCU cible.

C'est pourquoi les *starter kits* embarquent une sonde de programmation sur la carte, aux côtés du processeur cible. Il reste cependant la possibilité d'utiliser des sondes de programmation externes (ICD4, PICKIT4, ...) plus polyvalentes mais bien plus chères !

PIC18F27K40  
SPDIP 28 pins package

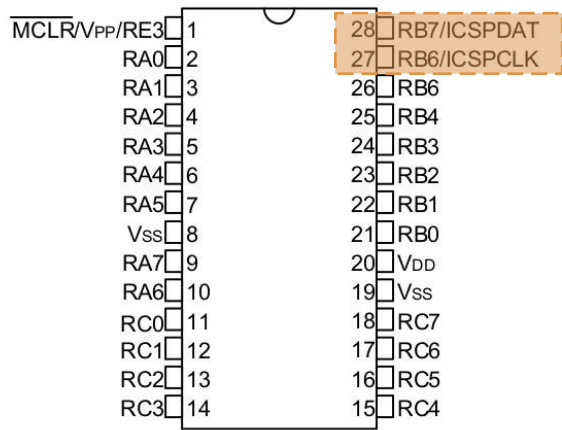

Curiosity HPC Starter kit  
With JTAG in-circuit programmer/debugger

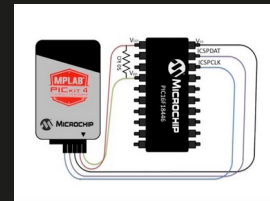
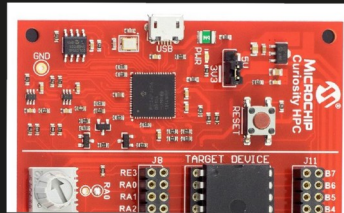

External PICKIT4  
JTAG in-circuit programmer/debugger



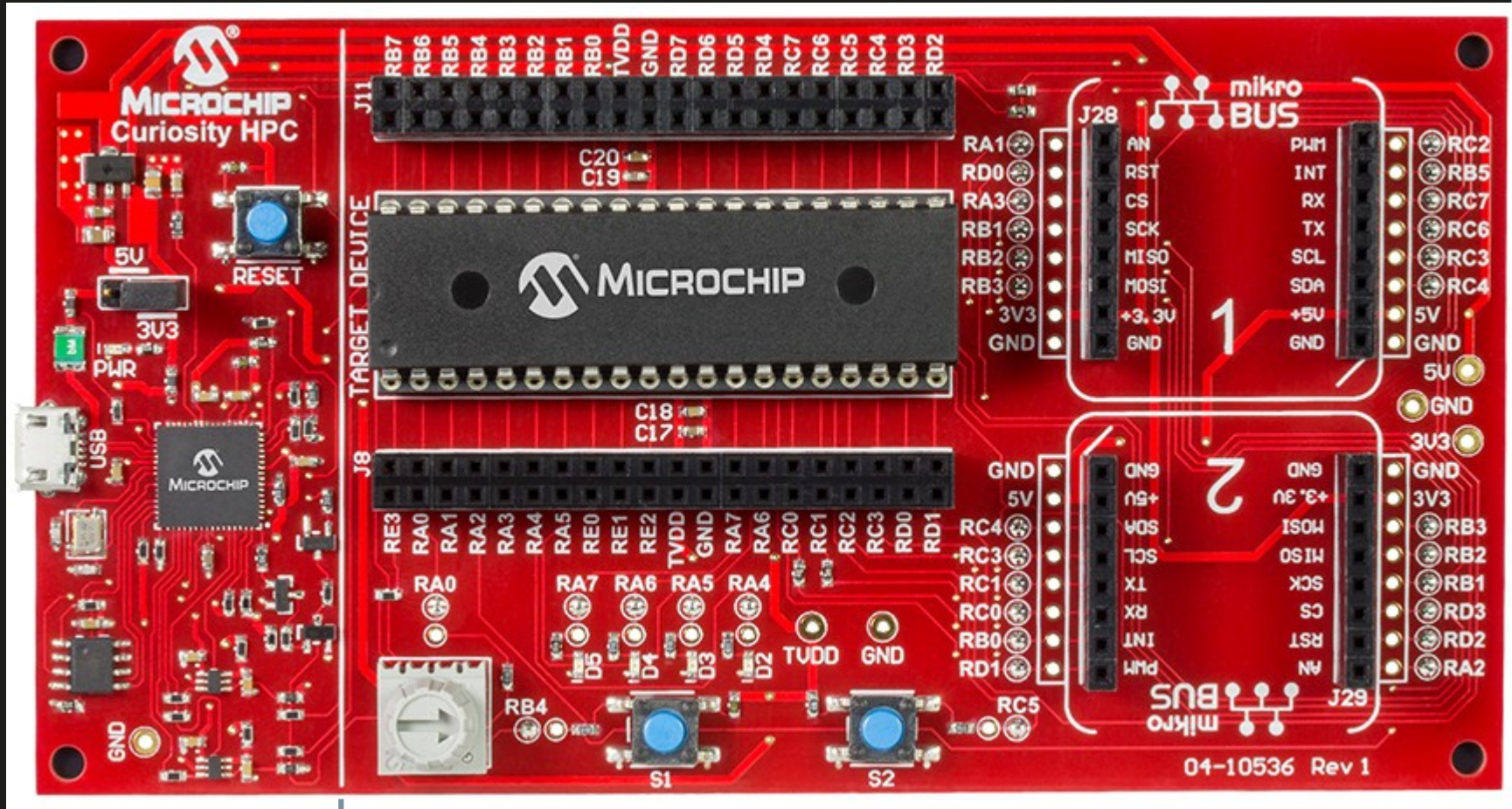

Programmer  
Debugger

Application







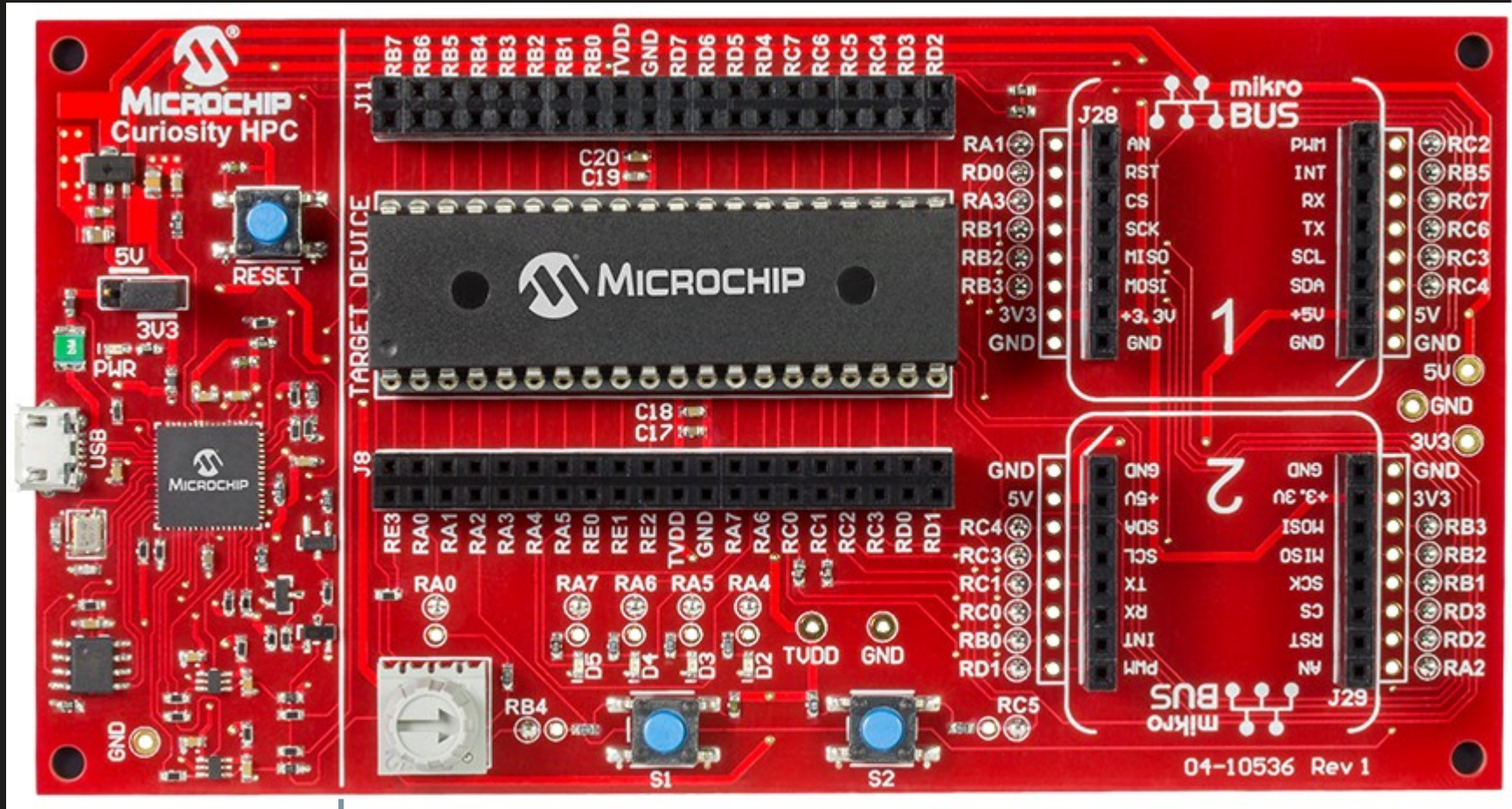

Programmer  
Debugger

Application



REV	ECO#	DESCRIPTION	DATE

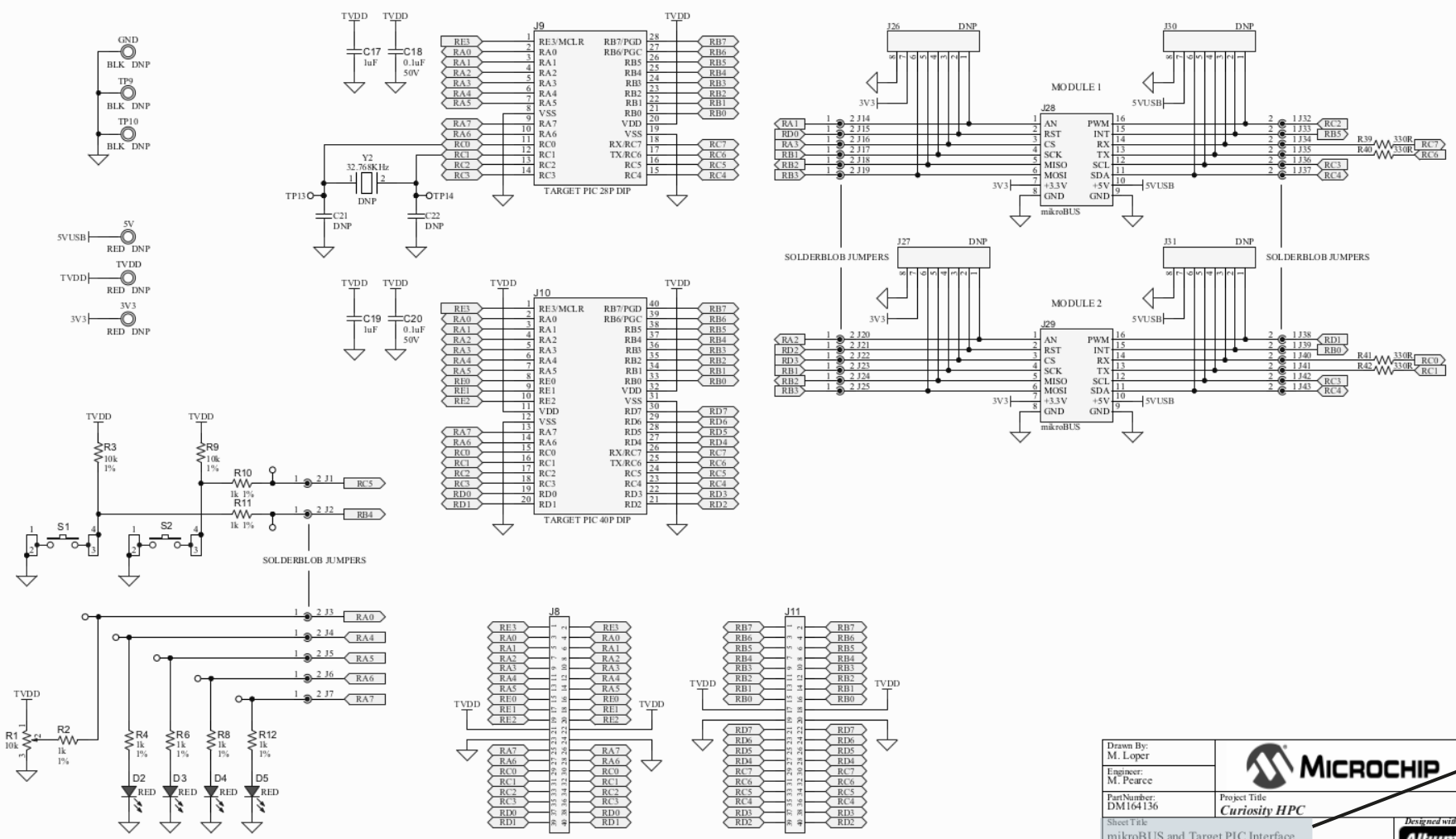

Cette page du schéma  
= partie MCU cible uniquement

Drawn By: M. Loper Engineer: M. Pearce	 <b>MICROCHIP</b> Project Title <b>Curiosity HPC</b>
Part Number: DM164136	Designed with  <b>Altium</b> Altium.com
Sheet Title <b>mikroBUS and Target PIC Interface</b>	
Size B	Sch # 03-10536 Date: 3/31/2016 10:48:21 AM Sheet 1 of 2
File: 00-103161 S03Doc	

REV	ECOR	DESCRIPTION	DATE

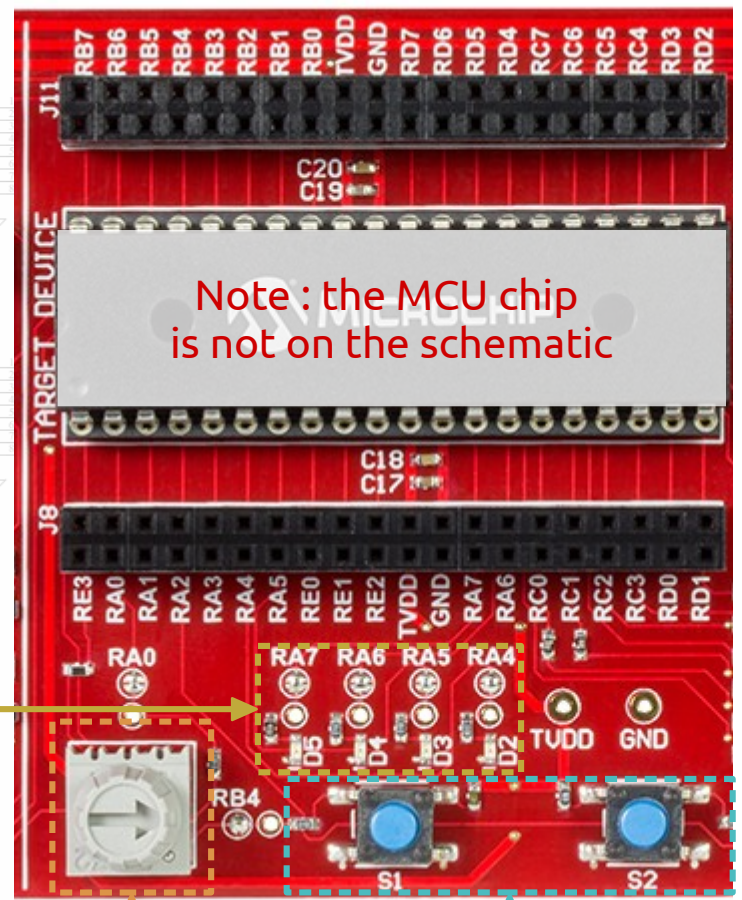
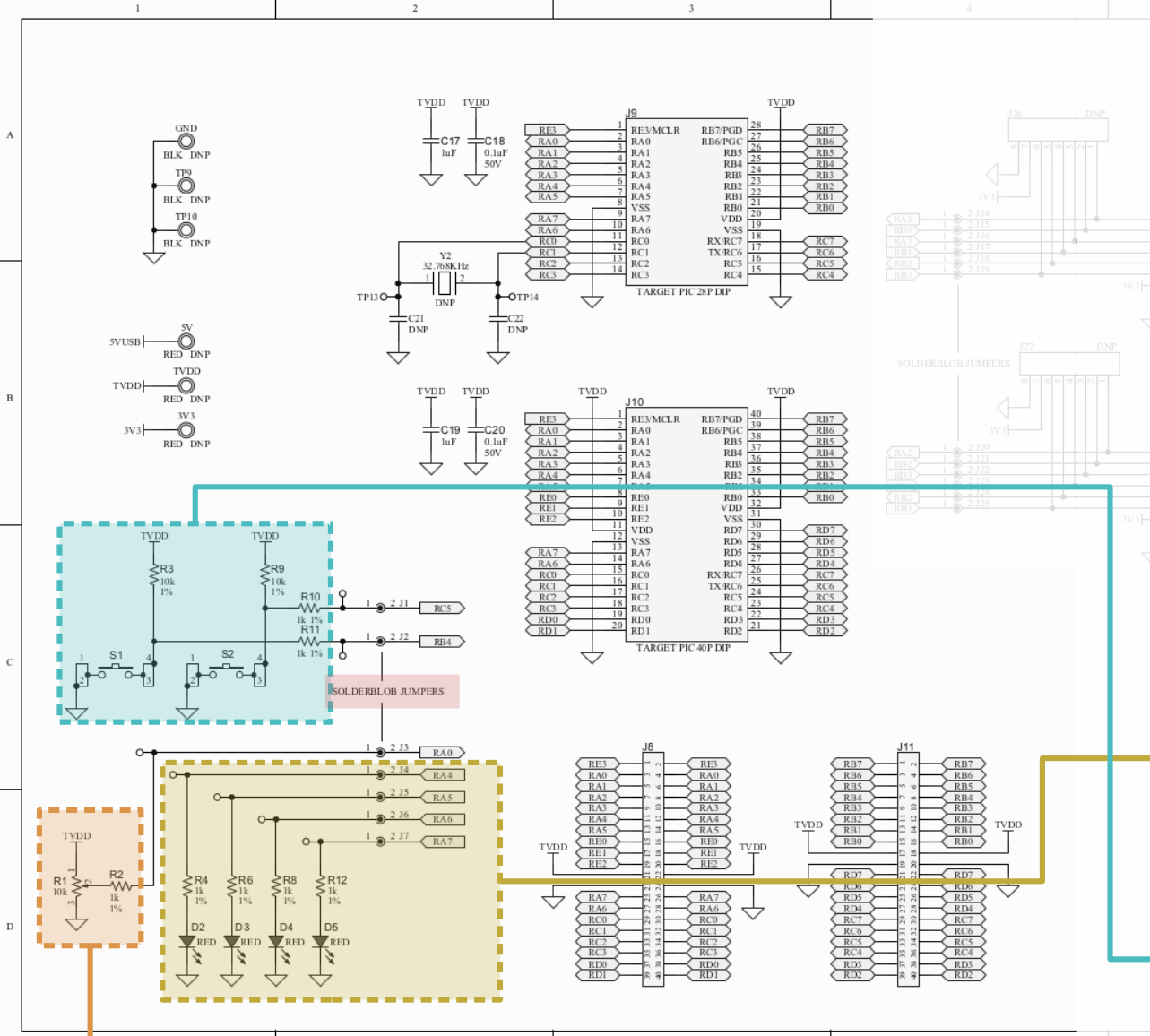

REV	ECOR	DESCRIPTION	DATE

### 28-pin DIP package MCU connector

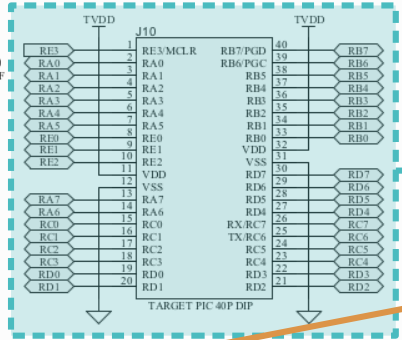
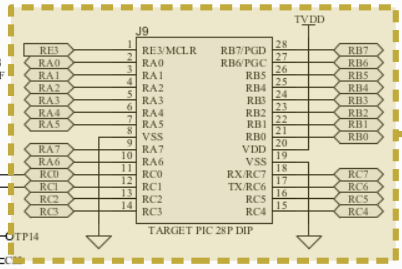

### 40-pin DIP package MCU connector

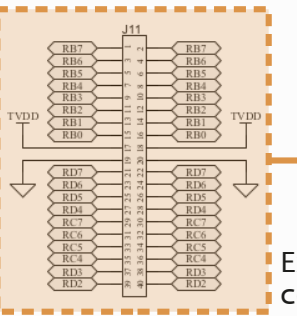
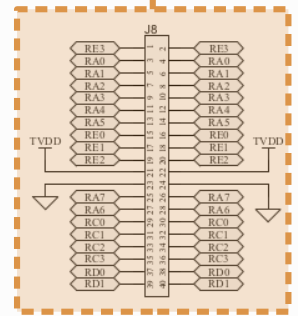
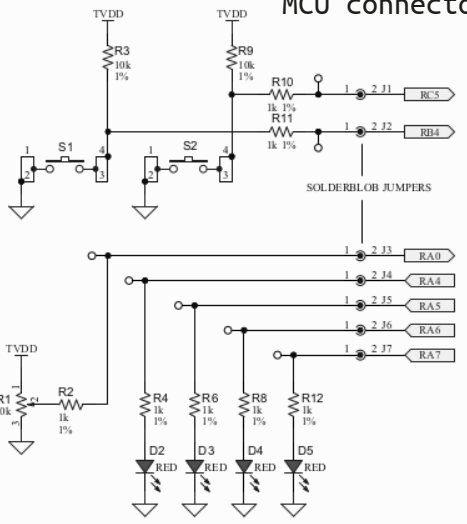

Expansion  
connectors

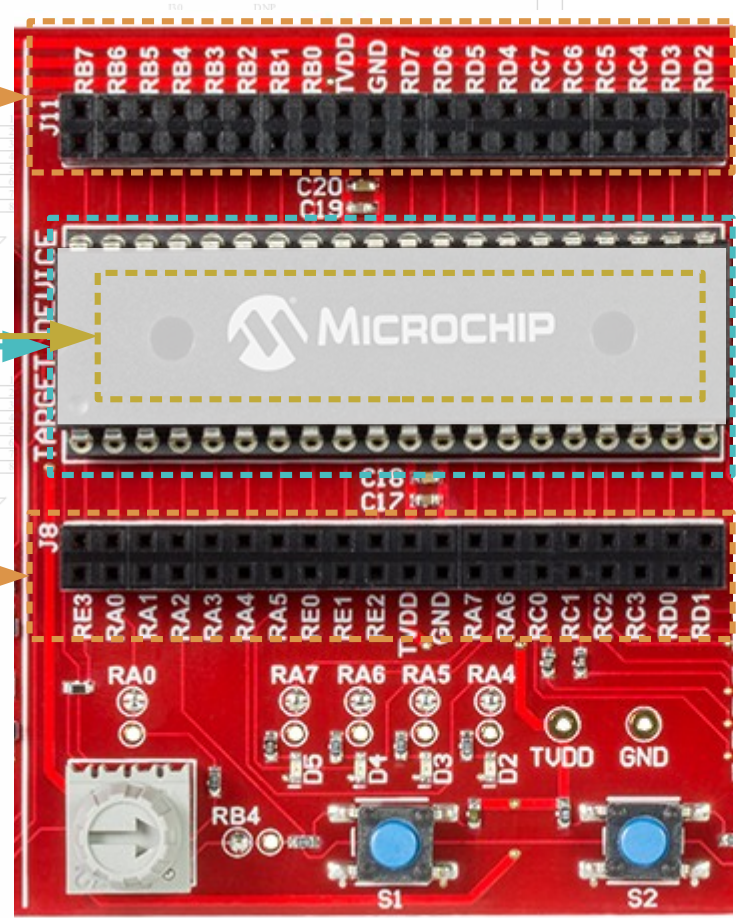

REV	ECO#	DESCRIPTION	DATE

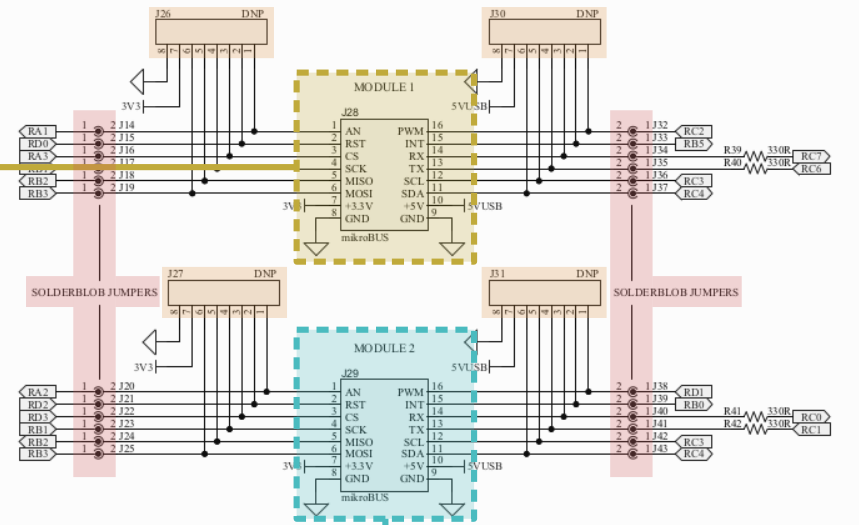
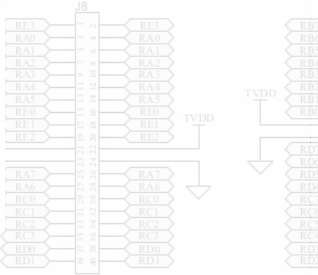
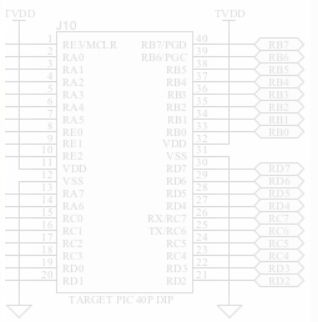
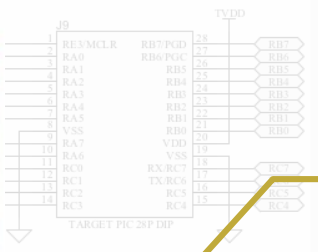
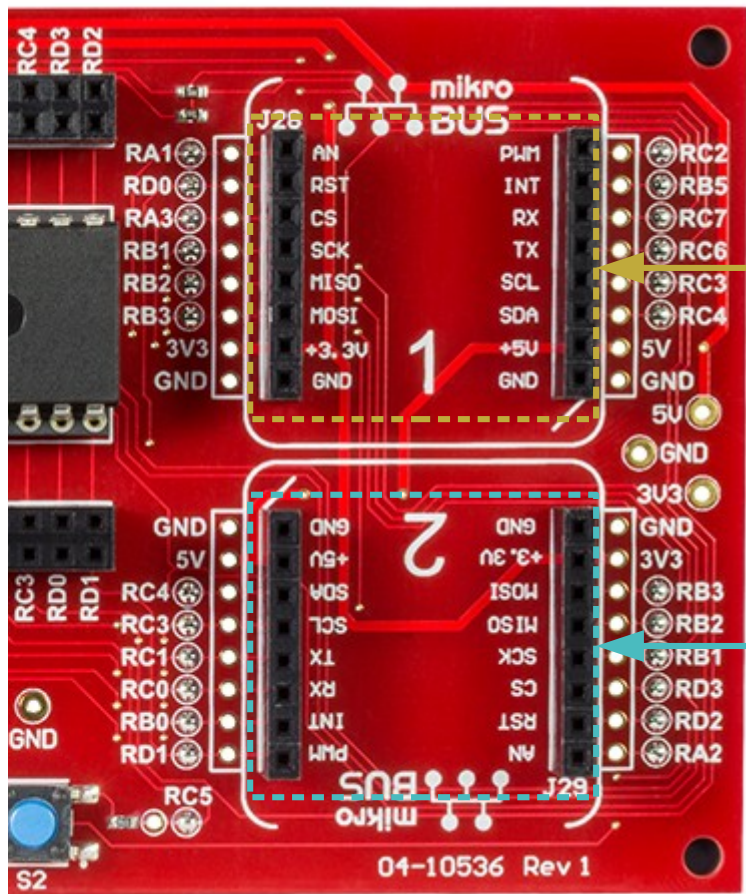

04-10536 Rev 1

Drawn By: M. Loper	<b>MICROCHIP</b>
Engineer: M. Pearce	
Part Number: DM164136	Project Title <b>Curiosity HPC</b>
Sheet Title <b>mikroBUS and Target PIC Interface</b>	
Size B	Sch # 03-10536
Revision 1	Date: 3/31/2016 10:48:21 AM
File: 01-035161 SchDoc	Sheet 1 of 2
<b>Altium</b> Designed with Altium.com	

## Prototypage avec modules Click Boards

La carte Curiosity HPC possède deux connecteurs mikroBUS permettant d'ajouter des modules externes Click Board proposés par la société Mikroelektronika. Des centaines de modules externes sont actuellement disponibles en catalogue (Bluetooth, audio, Wi-Fi, contrôle de moteur, afficheurs LCD, capteurs divers, ... ).

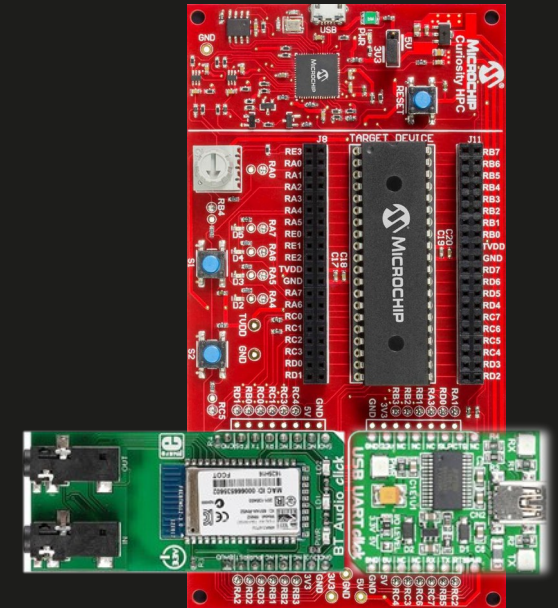
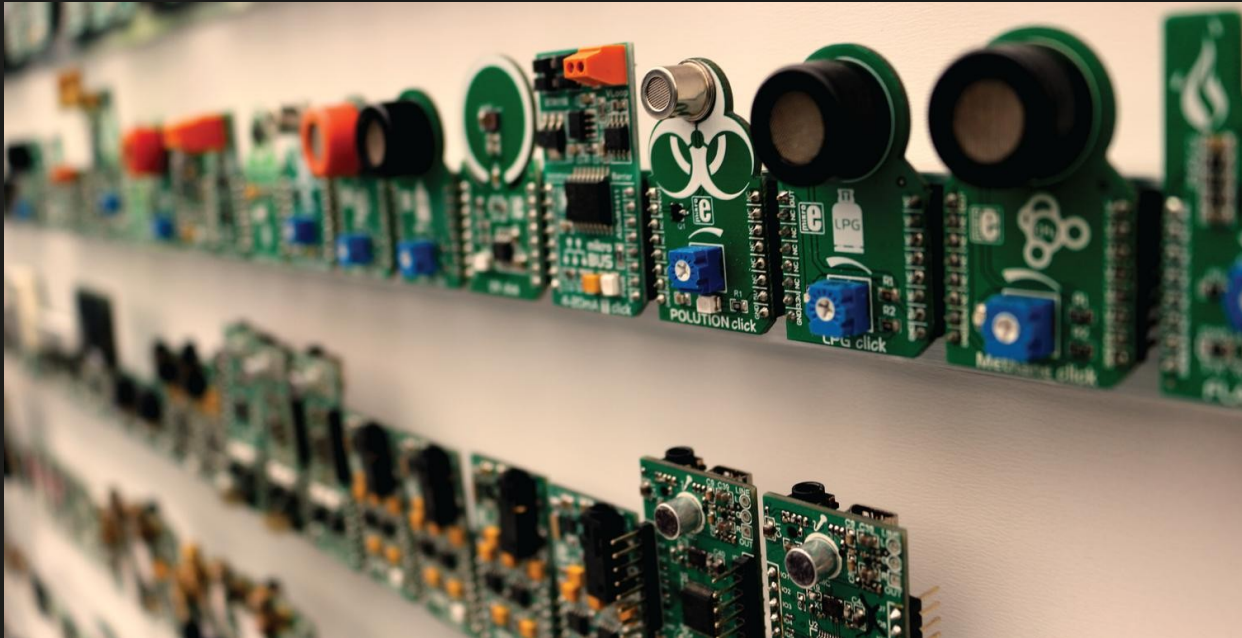

Comme la plupart des composants électroniques, un MCU peut être décliné en plusieurs boîtiers ou **packages** par le fabricant (DIP, BGA, QFN, SOP, ... ), chacun offrant en général un ensemble d'avantages et d'inconvénients.

Pour ces différents boîtiers, il est à noter que seul l'aspect physique change (encombrement, accessibilité des broches, dissipation thermique, prototypage ou production, techniques de dépose, etc). **La puce de silicium embarquée est la même.**

La Curiosity HPC, en tant que matériel de prototypage, est elle dédiée aux boîtiers DIP 28 ou 40 broches.



DIP : Dual In-line Package  
QFP : Quad Flat Package  
SOP : Small Outline Package  
PGA : Pin-Grid Array  
BGA : Ball-Grid Array  
QFN : Quad Flat No-lead

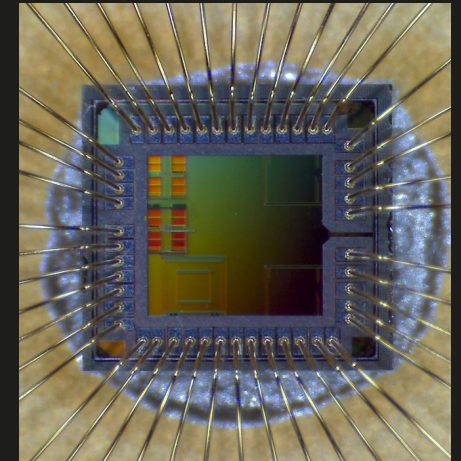

# PARTIE MCU CIBLE

## MCU Packages

